

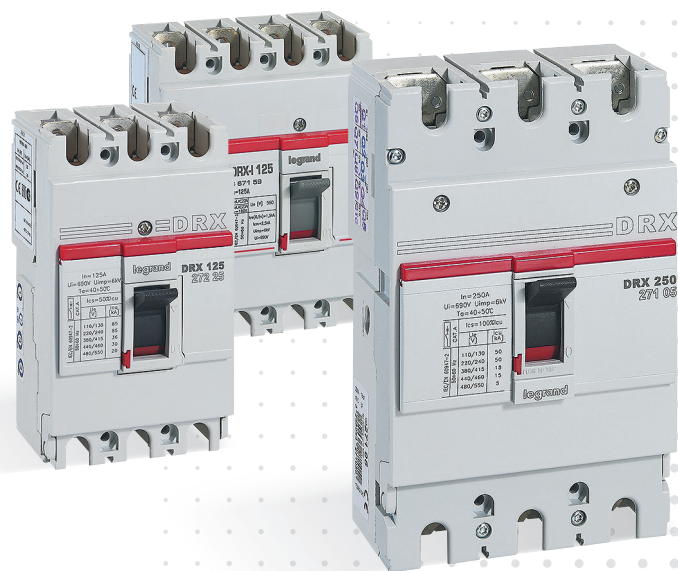

DRX

SIMPLY EFFICIENT
AND SAFE



CATALOGUE
PAGES
→ INSIDE

DRX 125 & 250
THERMAL MAGNETIC MCCBs
FROM 15 TO 250 A

DRX



A RANGE FROM 15 A TO 250 A

Designed to work in any type of environment, the DRX range of thermal magnetic circuit breakers has been conceived to meet your essential needs in terms of protecting an electrical installation up to 250 A.

For many years, the robust design of the DRX range has made it the ideal choice for efficiency and economy.

THE RANGE: THERMAL MAGNETIC MCCBs

Mounting

Rated current (In)

Breaking capacity (Icu) at 415 V \sim

Standard breaking capacity Ics (%Icu)

Number of poles

* From 15 to 100 A

A solution adapted to numerous different sites, whether residential or commercial buildings. Works in any type of environment, including in extreme temperatures.



THE BENEFITS OF THE DRX RANGE

THE CHOICE

- Two different sizes
- Ratings ranging from 15 to 250 A
- Several breaking capacities between 10 and 36 kA

ROBUST DESIGN

- SEMKO - LOVAG certification
- Compliant with standard IEC 60947-2 (for the circuit breakers) and IEC 60947-3 (for the trip free switches)
- Mechanical endurance up to 25,000 operations

ADAPTABILITY

- An exclusive system to change from the 50 mm standard to the 45 mm DIN standard
- Fixing on DIN rail or plate
- Wiring via cables or busbars
- Installation in any position
- Suitable for all environments (tropicalisation, pollution, salt corrosion, etc.)
- Operates in AC



DRX 125

ON RAIL OR ON PLATE

From 15 to 125 A

DRX 250



ON RAIL OR ON PLATE

From 125 to 250 A

10 kA	20 kA	36 kA	18 kA	25 kA	36 kA
100	75	50	100	75	50
3P - 4P	3P - 4P	1P* - 2P* - 3P - 4P	3P - 4P	3P - 4P	3P - 4P

SIMPLICITY EFFICIENCY ACCESSIBILITY

With just 2 circuit breaker sizes, the DRX range has it covered when it comes to providing protection against overloads and short-circuits, for sites up to 250 A.

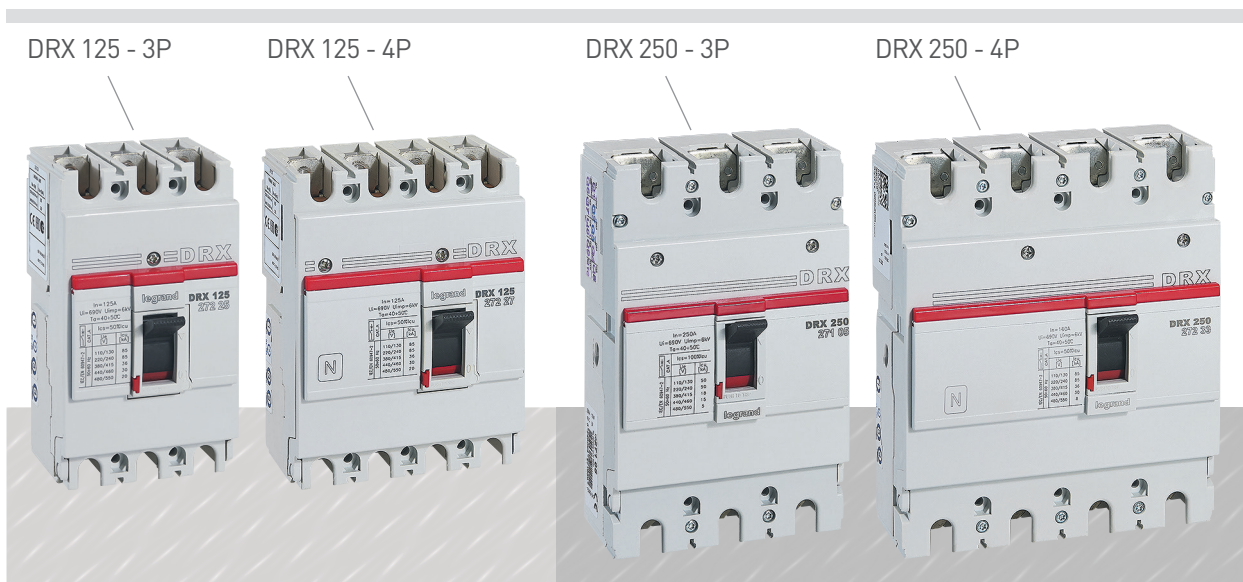

DRX



DRX-I 125 & 250

The DRX-I trip-free switches provide on-load circuit breaking and isolation of low voltage circuits.

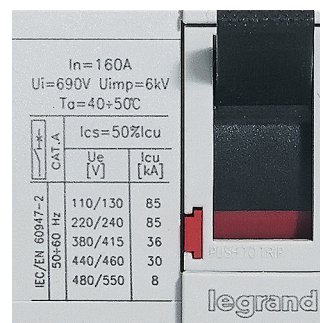

EASY IDENTIFICATION

Clear, simple, indelible marking on the front of the MCCB states the:

- thermal magnetic protection
- nominal current
- breaking capacity

ROBUST DESIGN

RELIABILITY

SAFETY

With the DRX range, you can guarantee long-term protection for your customers' installations. Its rugged construction ensures continuity of operation even in excessive temperatures.

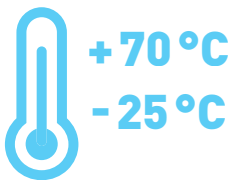

EXTREME TEMPERATURES

DRX MCCBs operate in extreme temperature conditions, between -25°C and +70°C, and need no temperature derating from 40°C to 50°C.

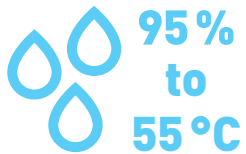

UTE C63100 GUIDE

Can be used in any type of environment: tropicalisation execution II (all climates, relative humidity between 95% and 55°C). Annex Q of IEC 60947-1 referred to:
 - IEC 60068-2-1 and 2-2
 - IEC 60068-2-30 and 2-52



ROBUST DESIGN

The DRX has proven mechanical endurance up to 25,000 operations.



SAFETY

No live parts are accessible once installed under a faceplate.



ROTARY HANDLE

The rotary handle, is available in direct or external version in order to accommodate different users' habits or the specific constraints affecting each type of site. It is simple and quick to fit.

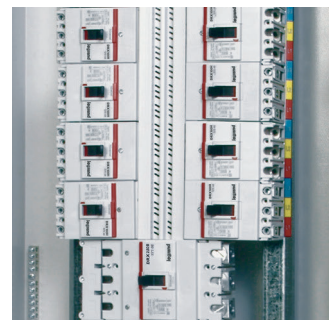

HORIZONTAL OPERATION

If required, DRX MCCBs can also be installed horizontally in enclosures like XL³-N 250.

EASE OF INSTALLATION AND WIRING

The DRX range includes numerous accessories which make wiring and installation easier and allow remote tripping, saving time during installation and enhancing safety.

EASE OF INSTALLATION AND FLEXIBILITY

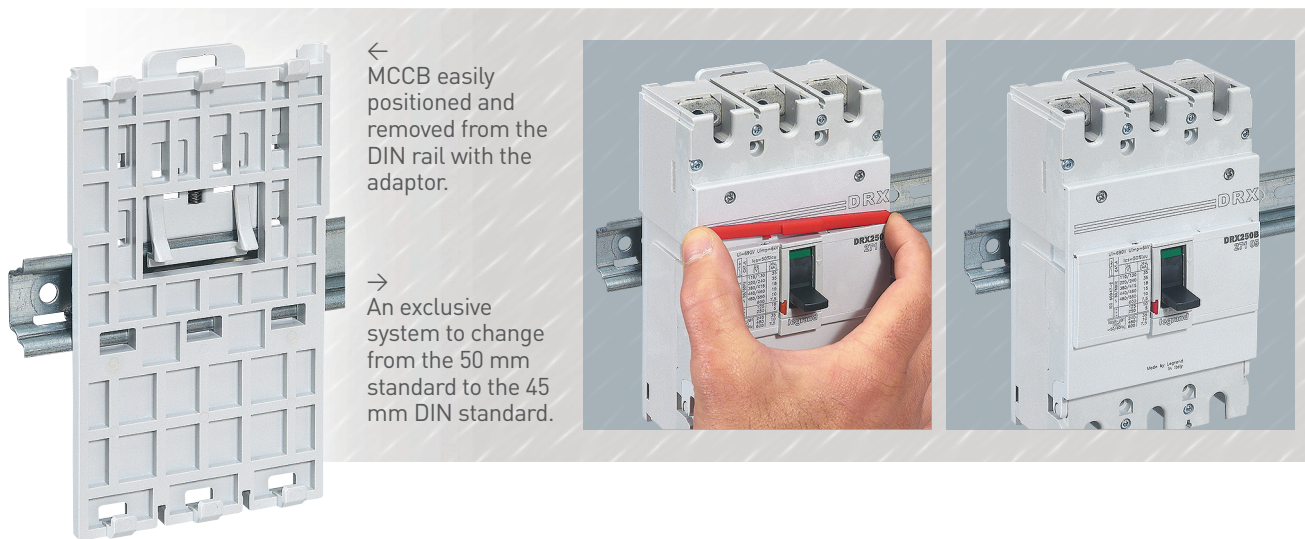

A VARIETY OF WIRING SYSTEM OPTIONS

24 mm distance between base and terminal, for mounting on busbars.

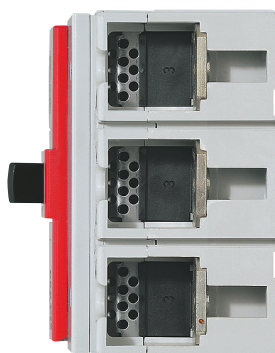

Cage terminals, insulating shields, terminal shields, etc; our wiring accessories cover most of your requirements.

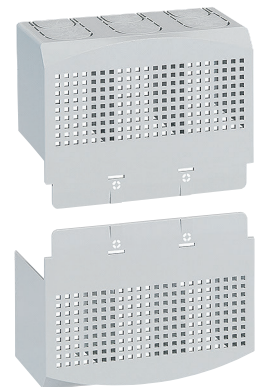

DRX

REMOTE TRIPPING FOR SAFETY

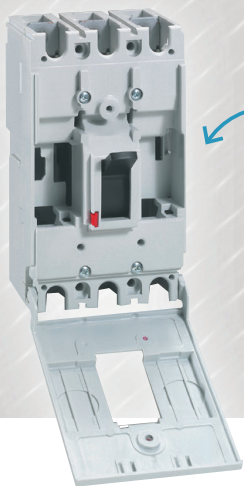

← Both the DRX 125 and 250 have a hinge so the front can open and close.

→ The control and signalling auxiliaries simply clip on.

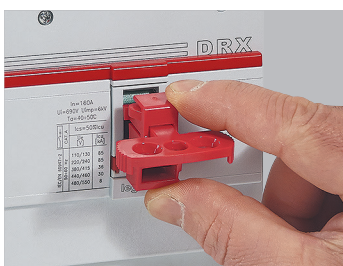
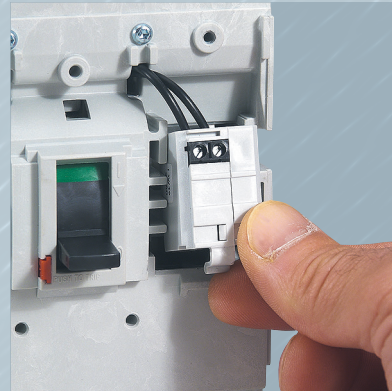

RISK-FREE INTERVENTION

The padlock can be used to lock the handle in "Open" position during maintenance operations and thus avoid any risk of accidents due to mishandling.



The DRX range can also be installed in XL³-N 250 enclosures as main circuit breaker

DRX™ 125

thermal magnetic MCCBs from 15 to 125 A



Technical characteristics and curves p. 7 to 9

For switching, control, isolation and protection of low-voltage electrical lines
Can be fitted with auxiliaries (p. 10)

Supplied with:

- M5 terminal for $I_n \leq 50$ A and M8 range for $I_n > 50$ A
- Fixing screws
- Insulating shields (2 for 3P and 3 for 4P)

Fixed thermal and magnetic

Conform to IEC 60947-2, in compliance with NEMA

Pack	Cat.Nos		DRX 125
			Breaking capacity Icu 10 kA (415 V~)
	3P	4P	In
1	0 270 00	0 270 10	15 A
1	0 270 01	0 270 11	20 A
1	0 270 02	0 270 12	25 A
1	0 270 03	0 270 13	30 A
1	0 270 04	0 270 14	40 A
1	0 270 05	0 270 15	50 A
1	0 270 06	0 270 16	60 A
1	0 270 39	0 270 29	63 A
1	0 270 07	0 270 17	75 A
1	0 272 55	0 272 56	80 A
1	0 270 08	0 270 18	100 A
1	0 270 09	0 270 19	125 A
			Breaking capacity Icu 20 kA (415 V~)
			In
1	0 270 20	0 270 30	15 A
1	0 270 21	0 270 31	20 A
1	0 270 22	0 270 32	25 A
1	0 270 23	0 270 33	30 A
1	0 270 24	0 270 34	40 A
1	0 270 25	0 270 35	50 A
1	0 270 26	0 270 36	60 A
1	0 272 20	0 272 22	63 A
1	0 270 27	0 270 37	75 A
1	0 272 57	0 272 58	80 A
1	0 270 28	0 270 38	100 A
1	0 272 21	0 272 23	125 A
			Breaking capacity Icu 36 kA (415 V~)
	1P	2P	In
1	0 270 40 ¹	0 270 50	15 A
1	0 270 41 ¹	0 270 51	20 A
1	0 270 42 ¹	0 270 52	25 A
1	0 270 43 ¹	0 270 53	30 A
1	0 270 44 ¹	0 270 54	40 A
1	0 270 45 ¹	0 270 55	50 A
1	0 270 46 ¹	0 270 56	60 A
1	0 270 47 ¹	0 270 57	75 A
1	0 270 48 ¹	0 270 58	100 A
	3P	4P	In
1	0 270 60	0 270 70	15 A
1	0 270 61	0 270 71	20 A
1	0 270 62	0 270 72	25 A
1	0 270 63	0 270 73	30 A
1	0 270 64	0 270 74	40 A
1	0 270 65	0 270 75	50 A
1	0 270 66	0 270 76	60 A
1	0 272 24	0 272 26	63 A
1	0 270 67	0 270 77	75 A
1	0 272 59	0 272 60	80 A
1	0 270 68	0 270 78	100 A
1	0 272 25	0 272 27	125 A

Pack	Cat.Nos		DRX-I 125
1	6 671 39	6 671 59	Trip-free switches for on-load circuit breaking and isolation of low voltage electrical circuits 125 A
			Mounting on rail
20	0 271 89		Plates for fixing DRX 125 on DIN rail For 1P
12	0 271 90		For 2P
6	0 271 87		For 3P and 4P
			Rotary handles
1	0 271 76		Direct on DRX Standard (grey)
1	0 271 77		Vari-depth handle Comprising: connecting rod, bracket, drilling template, mounting accessories, door locking mechanism Standard (grey)
			Connection accessories
			Insulating shields Used to isolate the connection between each pole Set of 2
1	0 271 81	0 271 82	Set of 3
			Sealable terminal shields Set of 2
1	0 271 91		Set of 2
	3P	4P	Cage terminals
1	0 271 83	0 271 84	Up to 50 A (inclusive)
1	0 271 70	0 271 72	From 60 to 100 A
1	0 271 71	0 271 73	For 125 A
1	0 272 52	0 272 53	Set of 60 pieces up to 50 A (inclusive)
1	0 271 92		Set of 60 pieces from 60 to 100 A
1	0 271 93		Set of 60 pieces 125 A
1	0 272 54		
			Padlock for DRX 125 and 250
1	0 271 80		For locking on "OFF" position (up to 3 locks)

1: Icu 25 kA (240 V~) for 1P

DRX™ 125

technical characteristics and curves

Curves

DRX 125 $I_{max} = 125 \text{ A}$ from 10 kA to 36 kA 3P - 4P

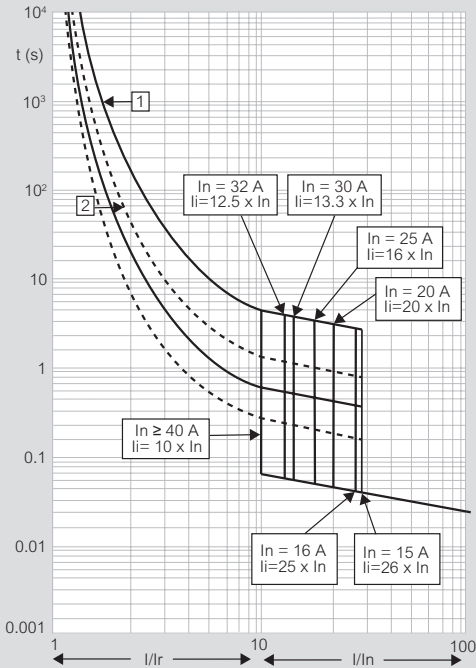

t = time
I = rated current
I_r = setting current
1 = characteristic with cold start
2 = characteristic with hot start

Pass-through specific energy characteristics

DRX 125 $I_{max} = 125 \text{ A}$ from 10 kA to 36 kA 3P - 4P at 415 V~

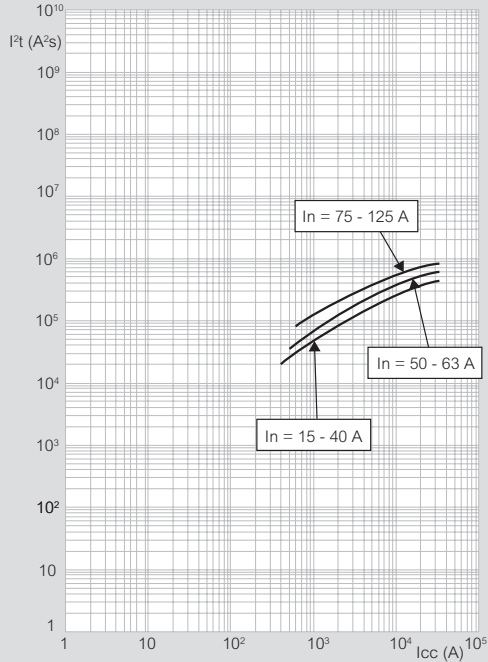

I_{cc} = estimated short circuit symmetrical current (RMS value)
 I^2t (A²s) = pass-through specific energy

Current limitation

DRX 125 $I_{max} = 125 \text{ A}$ from 10 kA to 36 kA 3P - 4P at 415 V~

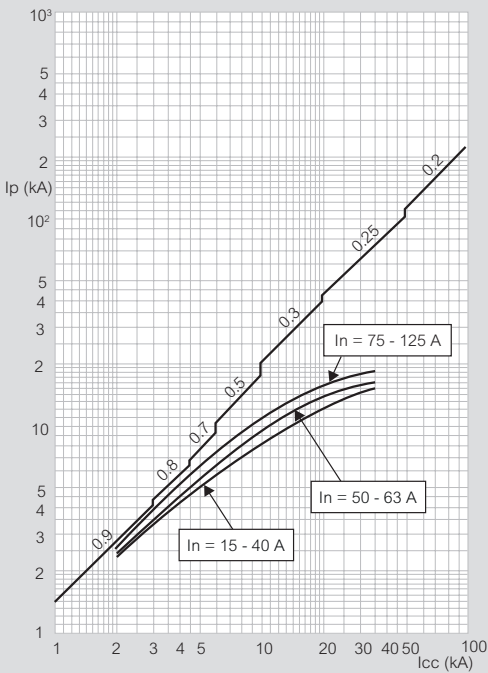

I_{cc} = estimated short circuit symmetrical current (RMS value)
 I_p = maximum short circuit peak current
— maximum prospective short circuit peak current corresponding at the power factor
— maximum real peak short circuit current by contact limiting effect

Technical characteristics

IEC/EN 60947-2 for circuit breakers ; IEC/EN 60947-3 for trip-free switches

	DRX 10 kA	DRX 20 kA	DRX 36 kA ⁽¹⁾	DRX 36 kA	DRX 36 kA	DRX-I 125
Number of poles	3P - 4P	3P - 4P	1P	2P	3P - 4P	3P - 4P
Rated current I_n (A)	15-125	15-125	15-100	15-100	15-125	125
Neutral protection for 4P version (%)	100	100	-	-	100	-
Rated insulation voltage U_i (V)	690	690	690	690	690	690
Rated impulse withstand current U_{imp} (kV)	6	6	6	6	6	6
Rated operating voltage (50/60 Hz) U_e (V)	550	550	550	550	550	550
Ultimate breaking capacity I_{cu} (kA)	110/130 V~	35	60	50	75	85
	220/240 V~	35	60	25	60	85
	277 V~	-	-	15	50	-
	380/415 V~	10	20	10	36	36
	440/460 V~	10	15	-	30	30
Ultimate breaking capacity I_{cu} (kA) NEMA AB-1	480/550 V~	7.5	10	-	20	20
	240 V~	35	60	25	60	85
Standard breaking capacity I_{cs} (% I_{cu})	100	75	50	50	50	-
Category of use	A	A	A	A	A	AC23A
Suitable for isolation	YES	YES	YES	YES	YES	-
Endurance (cycles)	mechanical	25000	25000	25000	25000	25000
	electrical at I_n	8000	8000	8000	8000	8000
	electrical at 0.5 I_n	10000	10000	10000	10000	10000

1: 1P - I_{cu} 25 kA (220/240 V~)
2: 2 poles in series

DRX™ 125

dimensions, mounting principle and connection

Dimensions

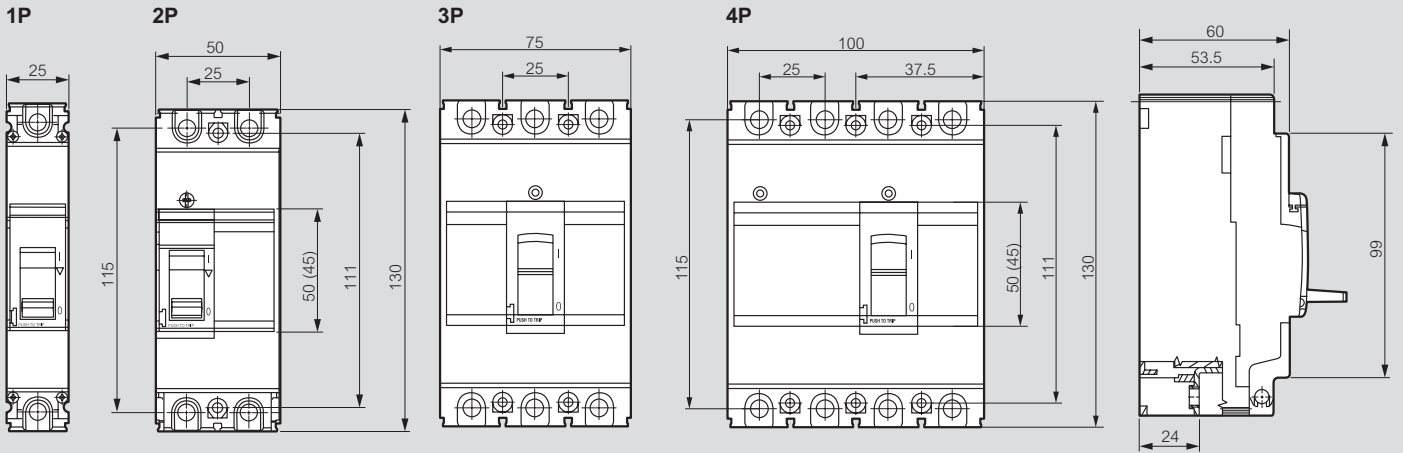

Mounting principle

Door cut-out

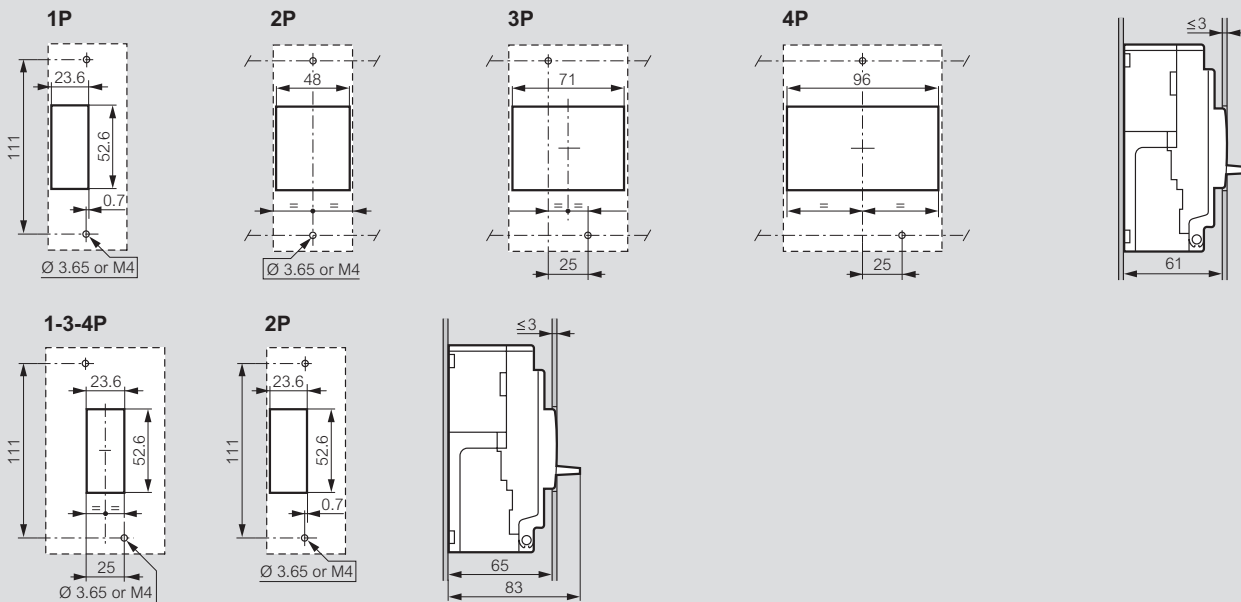

Auxiliary contacts

	Voltage (V)	Resistive load (A)
Vac	125	5
	250	5
Vdc	30	5
	50	1
	75	0.75
	125	0.5
250	0.25	
Mechanical endurance (No. of operations)	5 x 10 ⁶	
Temperature (°C)	- 40 to 85 °C	

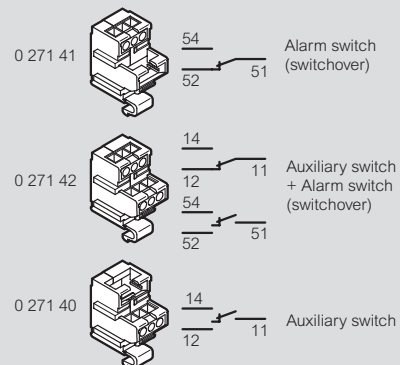

Mounting on DIN rail with plate

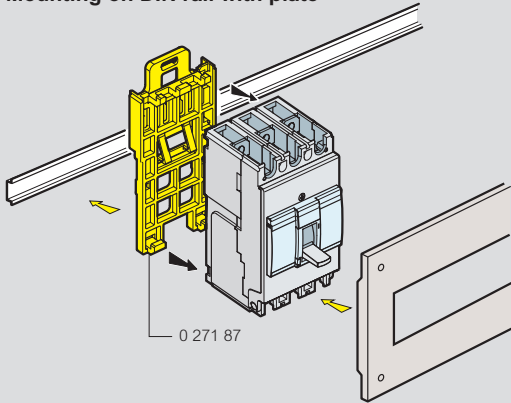

Fixing on plate

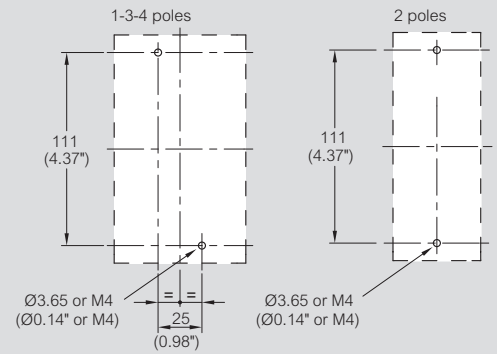
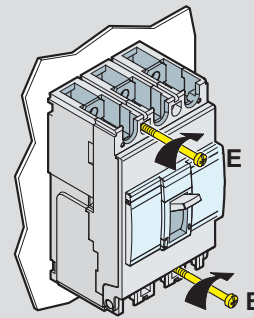

Connection

Connection via cable $I_n \leq 100 \text{ A}$

- $I_n \leq 50 \text{ A} = 0 271 70$ (3P)
- $0 271 72$ (4P)
- $0 271 92$ (set of 60 pieces)
- $50 \text{ A} < I_n \leq 100 \text{ A} = 0 271 71$ (3P)
- $0 271 73$ (4P)
- $0 271 93$ (set of 60 pieces)

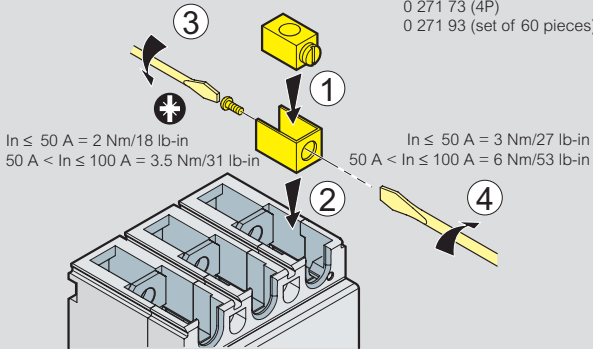

Connection via cable $I_n = 125 \text{ A}$

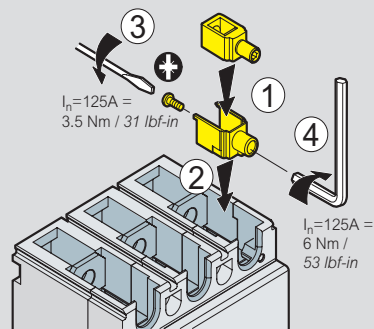

DRX ≤ 50 A	50 A < I_n ≤ 100 A	$I_n = 125 \text{ A}$
Flexible 2.5 → 10 mm ² #14 → #8 AWG	Flexible 10 → 35 mm ² #8 → #3/2 AWG	Flexible 35 → 50 mm ² #3/2 → #1/0 AWG
or Rigid 2.5 → 16 mm ² #14 → #6 AWG	Rigid 10 → 50 mm ² #8 → #1/0 AWG	Rigid 35 → 50 mm ² #3/2 → #1/0 AWG

2.5 to 4 mm² (#14 to #10 AWG) flexible cables connection via crimped end-barrels

Connection via busbar

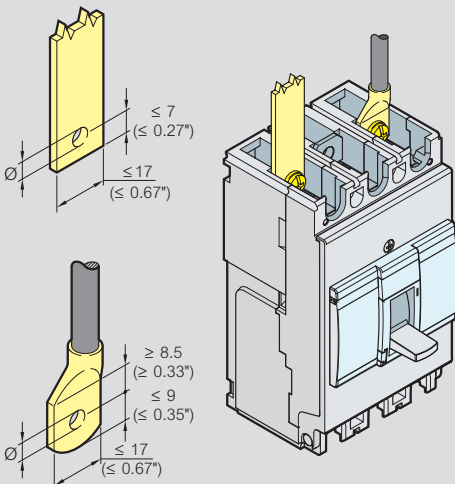

$I_n \leq 50 \text{ A}$	$50 \text{ A} < I_n \leq 125 \text{ A}$
Ø 5.5 mm / 0.21"	Ø 8.5 mm / 0.32"

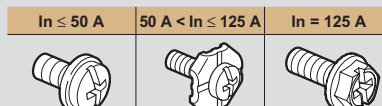

DRX™ 250

thermal magnetic MCCBs from 125 to 250 A

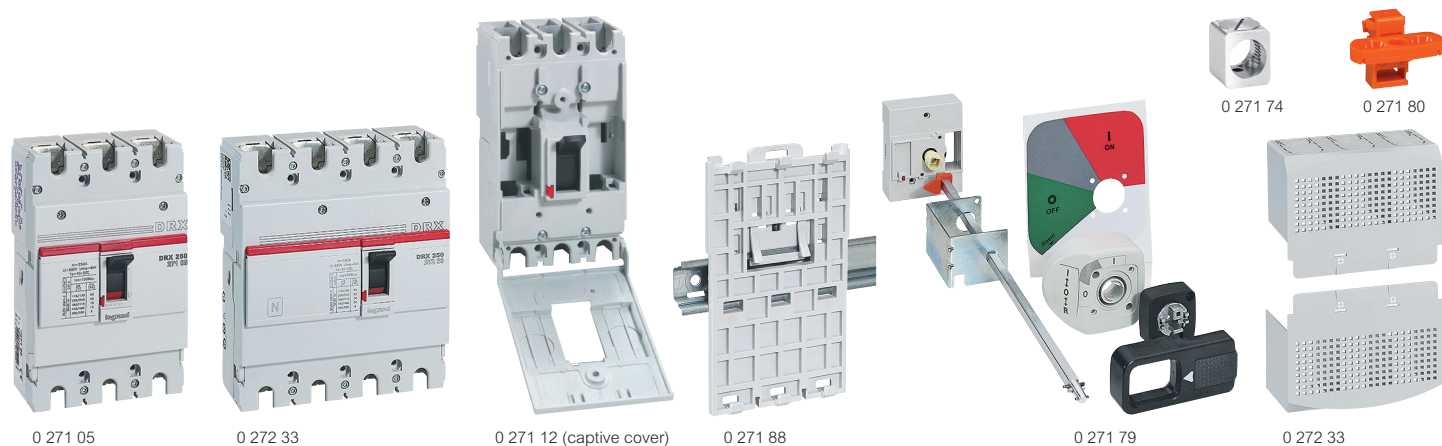

Technical characteristics and curves p. 11 to 13

For switching, control, isolation and protection of low-voltage electrical lines
 Can be fitted with auxiliaries
 Supplied with:
 - M8 terminals
 - Fixing screws
 - Insulating shields (2 for 3P and 3 for 4P)
 Fixed thermal and magnetic
 Conform to IEC 60947-2

Pack	Cat.Nos		DRX 250
	3P	4P	Breaking capacity Icu 18 kA (415 V~)
1	0 271 00	0 271 06	In 125 A
1	0 271 01	0 271 07	150 A
1	0 272 28	0 272 29	160 A
1	0 271 02	0 271 08	175 A
1	0 271 03	0 271 09	200 A
1	0 271 04	0 271 10	225 A
1	0 271 05	0 271 11	250 A
			Breaking capacity Icu 25 kA (415 V~)
			In 125 A
1	0 271 12	0 271 18	125 A
1	0 271 13	0 271 19	150 A
1	0 272 30	0 272 31	160 A
1	0 271 14	0 271 20	175 A
1	0 271 15	0 271 21	200 A
1	0 271 16	0 271 22	225 A
1	0 271 17	0 271 23	250 A
			Breaking capacity Icu 36 kA (415 V~)
			In 125 A
1	0 271 24	0 271 30	125 A
1	0 271 25	0 271 31	150 A
1	0 272 32	0 272 33	160 A
1	0 271 26	0 271 32	175 A
1	0 271 27	0 271 33	200 A
1	0 271 28	0 271 34	225 A
1	0 271 29	0 271 35	250 A

Pack	Cat.Nos		DRX-I 250
1	6 672 09	6 672 19	Trip-free switches for on-load circuit breaking and isolation of low voltage electrical circuits 250 A

Pack	Cat.Nos	Mounting on rail
1	0 271 88	Plate for fixing DRX 250 on DIN rail

Pack	Cat.Nos	Rotary handles
1	0 271 78	Direct on DRX Standard (grey)
1	0 271 79	Vari-depth handle Comprising: connecting rod, bracket, drilling template, mounting accessories, door locking mechanism Standard (grey)

Pack	Cat.Nos	Connection accessories
		Insulating shields Used to isolate the connection between each pole Set of 2 Set of 3
1	0 271 81	Set of 2
1	0 271 82	Set of 3
		Sealable terminal shields Set of 2
1	0 271 85 0 271 86	
		Cage terminals Up to 250 A Set of 60 pieces
1	0 271 74 0 271 75	
1	0 271 94	
		Padlock for DRX 125 and 250 For locking on "OFF" position (up to 3 locks)
1	0 271 80	
		Control and signalling auxiliaries for DRX 125 and 250
		Auxiliary contact blocks For left-hand side mounting Up to 250 V~ and =
1	0 271 40	Block with 1 auxiliary
1	0 271 41	Block with 1 alarm
1	0 271 42	Block with 1 auxiliary + 1 alarm
		Shunt trips
1	0 271 50	12 V~ and =
1	0 271 51	24 V~ and =
1	0 271 52	48 V~ and =
1	0 271 53	100/130 V~
1	0 271 54	200/277 V~
1	0 271 55	380/480 V~
		Undervoltage releases
1	0 271 60	12 V~ and =
1	0 271 61	24 V~ and =
1	0 271 62	48 V~ and =
1	0 271 68	110 V=
1	0 271 63	110/130 V~
1	0 271 64	200/240 V~
1	0 271 67	277 V~
1	0 271 65	380/415 V~
1	0 271 66	440/480 V~

DRX™ 250

technical characteristics and curves

Curves

DRX 250 $I_{max} = 250 \text{ A}$ from 18 kA to 36 kA 3P - 4P

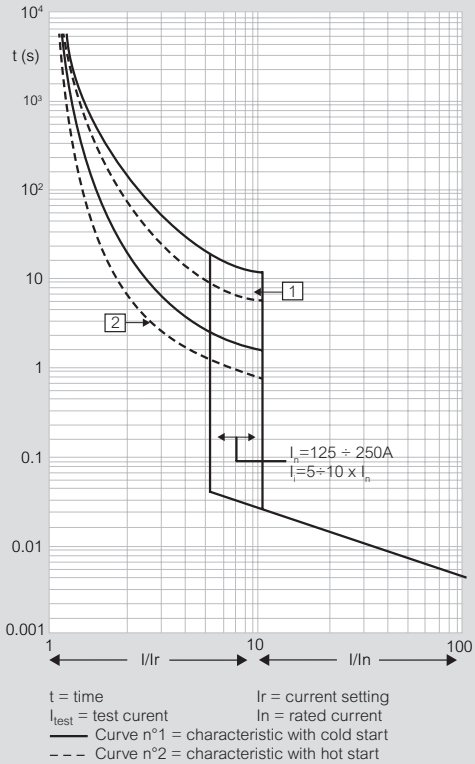

Pass-through specific energy characteristics

DRX 250 $I_{max} = 250 \text{ A}$ from 18 kA to 36 kA 3P - 4P at 415 V~

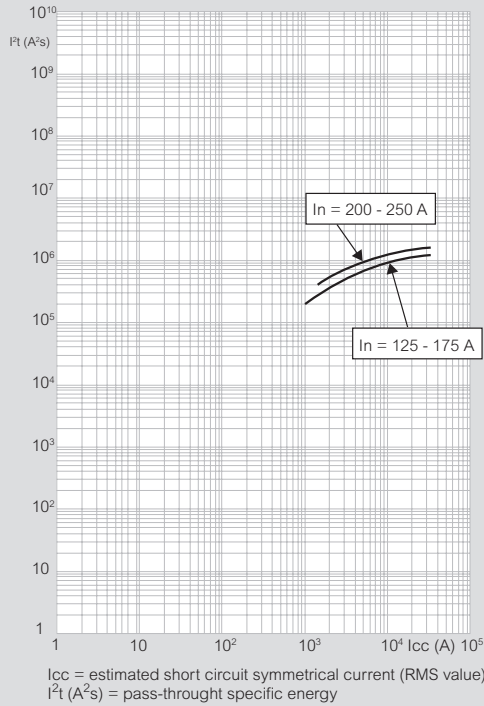

Current limitation

DRX 250 $I_{max} = 250 \text{ A}$ from 18 kA to 36 kA 3P - 4P at 415 V~

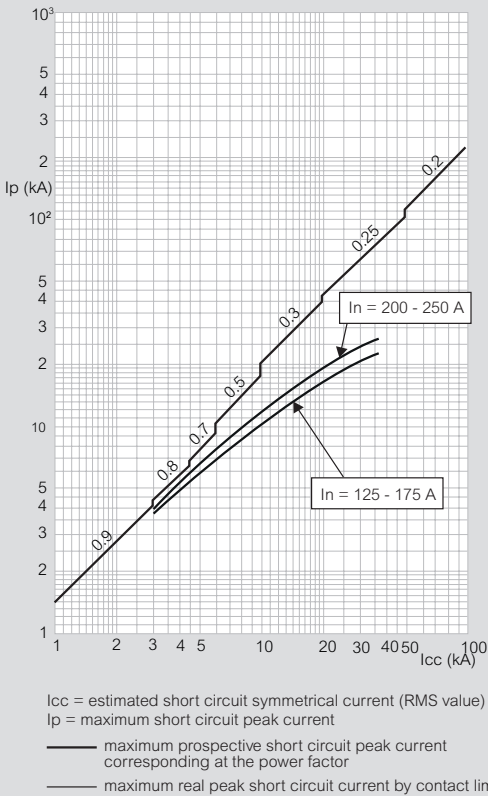

Technical characteristics

IEC/EN 60947-2 for circuit breakers ; IEC/EN 60947-3 for trip-free switches

	DRX 18 kA	DRX 25 kA	DRX 36 kA	DRX-I 250
Number of poles	3P - 4P	3P - 4P	3P - 4P	3P - 4P
Rated current I_n (A)	125-250	125-250	125-250	250/160
Neutral protection for 4P version (%)	100	100	100	-
Rated insulation voltage U_i (V)	690	690	690	690
Rated impulse withstand current U_{imp} (kV)	6	6	6	6
Rated operating voltage (50/60 Hz) U_e (V)	550	550	550	550
Ultimate breaking capacity I_{cu} (kA) IEC 60947-2	110/130 V~	35	70	85
	220/240 V~	35	70	85
	380/415 V~	18	25	36
	440/460 V~	15	22	30
Ultimate breaking capacity I_{cu} (kA) NEMA AB-1	480/550 V~	5	6	8
	240 V~	35	70	85
Standard breaking capacity I_{cs} (% I_{cu})	100	75	50	-
Category of use	A	A	A	AC22A/AC23A
Suitable for isolation	YES	YES	YES	YES
Endurance (cycles)	mechanical	20000	20000	20000
	electrical at I_n	8000	8000	8000
	electrical at 0.5 I_n	10000	10000	10000

DRX™ 250

dimensions, mounting principle and connection

Dimensions

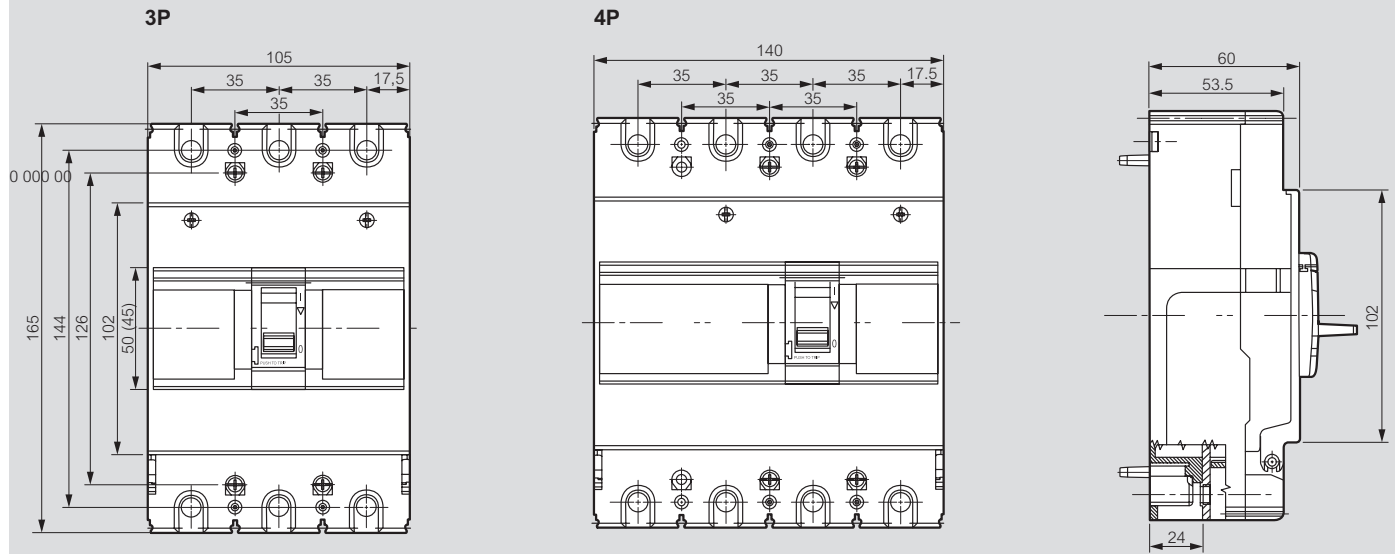

Mounting principle

Door cut-out

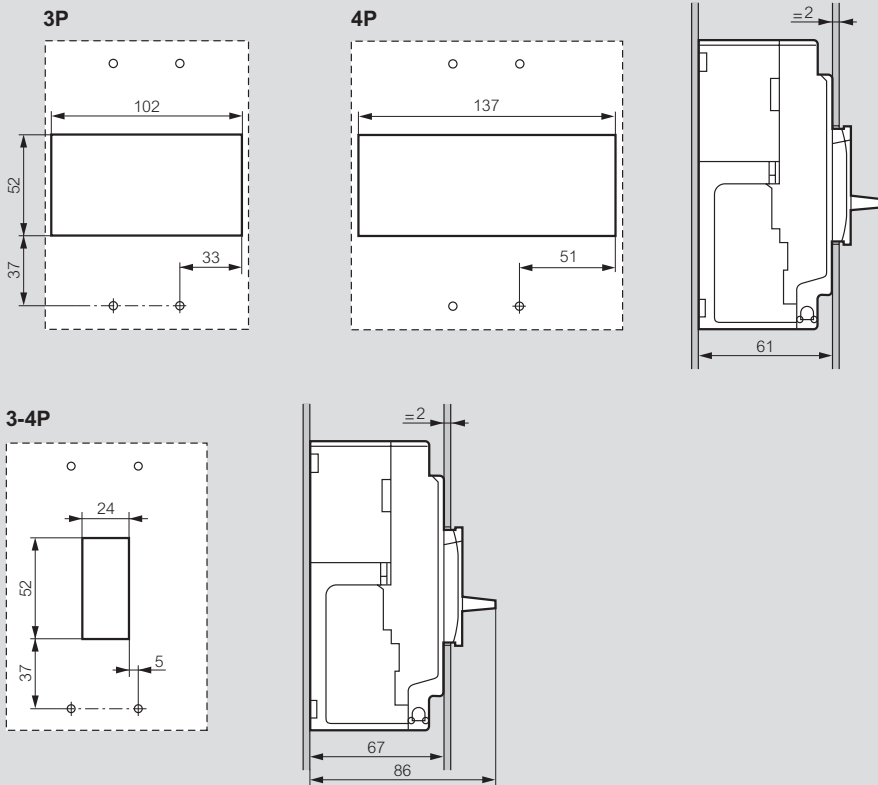

Mounting on DIN rail with plate

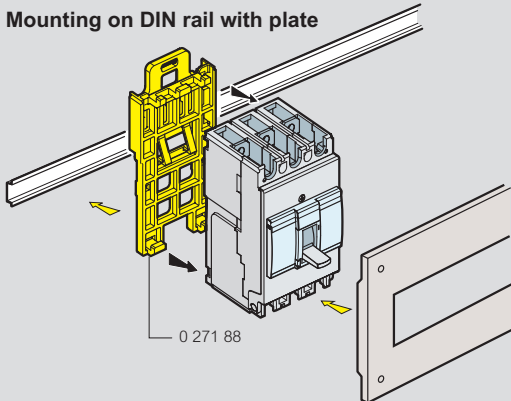

Fixing on plate

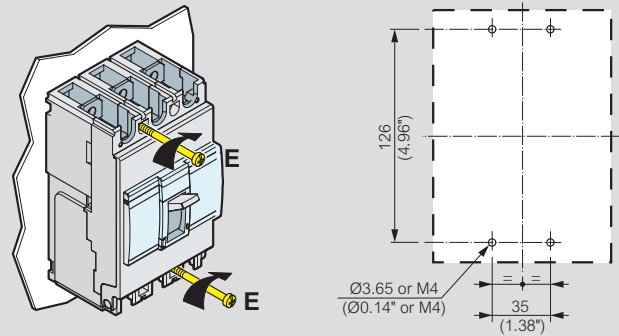

Connection

Connection via busbar

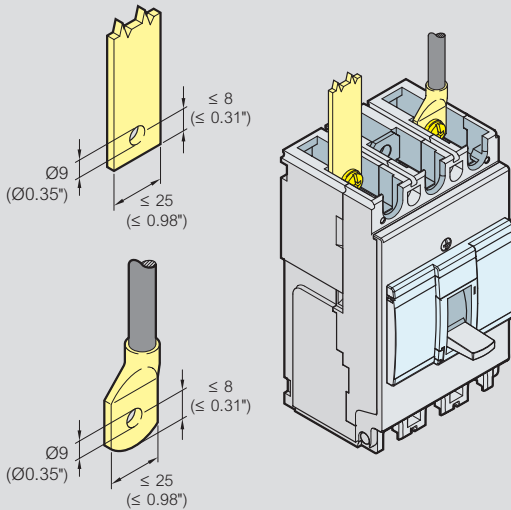

Connection via cable

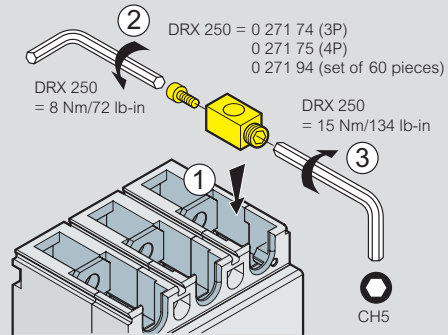

DRX 250 - 125 to 250 A

Flexible
 35 mm² ⇒ 120 mm²
 #2 ⇒ #250 MCM
 or
 Rigid
 35 mm² ⇒ 150 mm²
 #2 ⇒ #300 MCM

Auxiliary contacts

	Voltage (V)	Resistive load (A)
Vac	125	5
	250	5
Vdc	30	5
	50	1
	75	0.75
	125	0.5
250	0.25	
Mechanical endurance (No. of operations)		5 x 10 ⁶
Temperature (°C)		- 40 to 85 °C

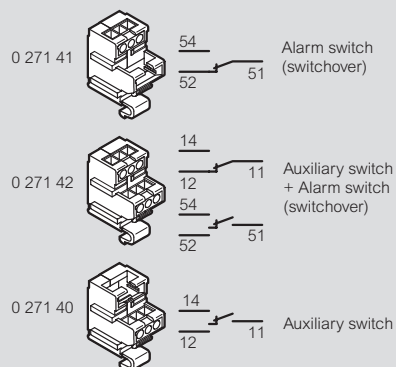



FOLLOW US ALSO ON

@ website: www.legrand.eg

f legrand

@ legrandegypt

EXB 17007 - March 2017



EMB Electrical Industries S.A.E.

Headquarter office

Pyramids Heights Office Park
KM 22 Cairo - Alex. desert road
Building 1B, 12556
Tel.: +202 3536 0000
Fax: +202 3536 0001
www.legrand.eg